

1.5 kW — 14 kW SINGLE PHASE

UltraLITE **MODEL ELU**

Centralized Emergency Lighting Inverters

Seamless transfer, online double-conversion system,
compatible with all existing lighting applications.

Meets NFPA 101, 111, NEC, IBC and local codes.

Applications:

- Schools / Universities / Dormitories
- Security / Public Address Systems
- Arenas / Stadiums
- Subways / Mass Transit
- Parking Structures / Garages
- Hospitals / Clinics
- Office Buildings
- Shopping Malls
- Airport Terminals
- Casinos / Resorts
- Hotels / Motels
- Apartment Buildings
- Correctional Facilities

 UL 924
UL 1778 / cUL



CONTROLLED POWER COMPANY

EMERGENCY LIGHTING REQUIREMENTS

The “UltraLITE, Model ELU” = Life Safety

Apart from the existing emergency lighting codes, many U.S. cities and states have adopted legislation that requires buildings with 5 or more units of occupancy to have a **centralized emergency lighting system**, where single-point operation controls a facility’s many smaller circuits, and all testing and record-keeping of the emergency power equipment is performed from one location.

Meeting stringent requirements in construction and performance, Controlled Power Company’s self-diagnostic, self-testing, **UltraLITE centralized emergency lighting inverters** are UL 924 listed as “Emergency Lighting Equipment” and “Auxiliary Power Supplies”, as well as NFPA compliant as “Life Safety Equipment”.

The **UltraLITE** offers more security and versatility to meet illumination requirements, and is the perfect complement for all life safety and lighting applications — “the universal solution”.

Our inverter technology effectively maintains critical equipment with extended brownout protection, tight voltage regulation, and power conditioning. Tight voltage regulation assures that facility egress lumens are maintained 100% at emergency lighting fixtures, in all modes of operation, and also extends ballast and lamp life.

Major Advantages Of The “UltraLITE, Model ELU”

Design Flexibility

Using existing fixtures for emergency lighting and egress assures compliance with minimum illumination code requirements. Extensive combinations of input and output voltages, timed off bus with remote “command on” control, automatic battery testing, and control device override options make the **UltraLITE** one of the most versatile and dependable lighting inverter systems in the market.

Single Point Operation / Maintenance

One central inverter controls many smaller circuits. Cost-effective, single-point operation provides a common battery pack, and enables all maintenance to be performed and records to be logged from a single location. Additional benefits include:

- Egress lighting integrity test.
- Hot-swappable battery replacement.
- Standard internal bypass.
- Maintenance-free, standard 15-year pro-rated batteries.

Premium Power And Voltage Regulation

Maintains proper operating voltage for HID and high-pressure sodium lighting, as well as electronic ballasts, resulting in:

- Voltage sag and surge protection.
- Longer wire runs without upsizing the wire. Regulated voltage source minimizes voltage drop.
- Less-frequent replacement of ballasts and lamps.
- Facility egress lumens are maintained 100% (will not diminish) over the full 90 minutes of emergency power.

Generator-Compatible

The **UltraLITE** is listed “UL924 Auxiliary Power Supplies”, and is suitable to provide uninterrupted back-up power until a generator starts. Even with an extremely distorted input waveform, the output of the **UltraLITE** delivers a clean sinewave, with no more than 3% THD, without switching to batteries. This feature also extends ballast and lamp life.

Reduced Utility Expense

Energy conservation continues to be a prevalent issue. The **UltraLITE** provides several energy-saving solutions without compromising life safety requirements.

- Provides local control of life safety to reduce / eliminate unnecessary night-light circuits and “always on” lighting loads.
- Provides multiple, independent zone sensing abilities to reduce / eliminate unnecessary multiple-floor and multiple building-wing illumination.

All of these advantages result in the best reliability and net performance of your lighting system!

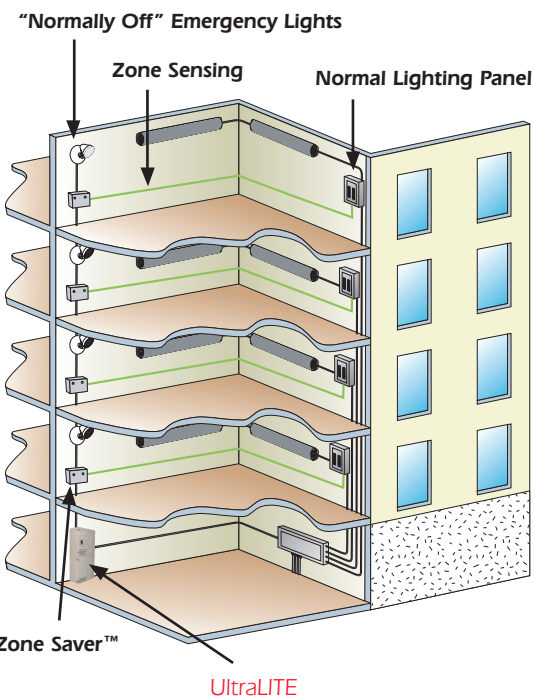

SYSTEM DESCRIPTION & SPECIFICATIONS

Controlled Power Company engineers and manufactures the industry's highest quality **centralized emergency lighting inverters**, capitalizing on 4 decades of expertise. We have an enviable reputation for quality, which is reflected in the design, workmanship, and performance of our products.

Providing a seamless transfer to back-up power for your emergency lighting system, the **UltraLITE** is compatible with all fixtures including HID, metal halide, high-pressure sodium, quartz / mercury vapor, halogen, fluorescent, and incandescent lighting applications. The voltage regulation and performance characteristics of the **UltraLITE** offer a significant advantage over competing products.

Features & Benefits

- Uninterrupted, regulated, continuous sinewave output for use with "normally on" lighting fixtures and exit lamps.
- Standby output for use with "normally off" emergency lighting fixtures.
- Pulse width modulation and IGBT technology provide tight output voltage regulation.
- Delivers highly-filtered, regulated, and spike-free power to emergency lighting fixtures and "Life Safety" devices.
- True, online double-conversion topology provides conditioned, regulated power and 100% reliability to emergency lighting loads.
- Auxiliary input command.
- High-speed static bypass.
- System approved for 42k AIC rated source.
- Variable-range logic provides added security during deep brownout conditions, without battery consumption — thus assuring that the batteries will be at full capacity for a power outage.
- Field-modifiable distribution.
- Short-circuit protected.
- NEMA 1 enclosure.
- Generator-compatible.
- 4-stage, temperature compensating smart charge.
- Optional control device override (wall switch, occupancy sensor, dimmer, etc).
- Optional zone sensing.
- Optional remote status panel and automatic phone dialer.
- Optional network connectivity.

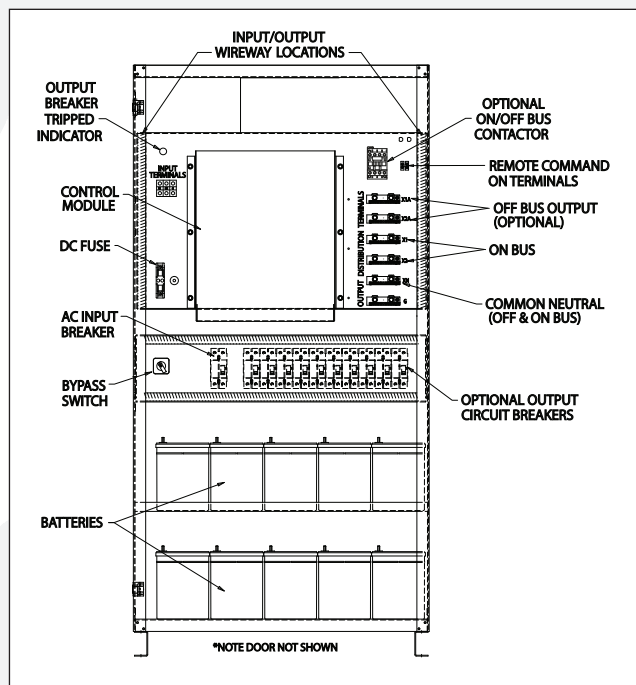

Safety

- UL 924 Emergency Lighting Equipment
- UL 924 Auxiliary Power Supplies
- UL 1778 Uninterruptible Power Supplies
- cUL listed to CSA standard C22.2 No.107.1-01 General Use Power Supplies
- NFPA 101, NFPA 111, NEC, and local codes

Product Specifications

- Input Operating Voltage Range: +12%, -30% typical, load-dependent without battery usage
- Input Frequency: 60 Hz, $\pm 2.5\%$
- Input Current Harmonic Distortion: <5% THD
- Input Power Factor Correction: > .99 PF
- Output Sine Wave Voltage: Typical 3% output THD with linear load
- Output Regulation: Typically better than $\pm 1.5\%$
- Output Circuit Breaker Pole Spaces Available:
 - Without Trip Indicator Alarm / Light: 20
 - With Trip Indicator Alarm / Light: 10
- Standard Unit Operating Temperature: 0° C to 40° C
- Total System MTBF: Approx. 100,000 hours
- Audible Noise: < 50 dB
- Noise Attenuation:*

Common Mode: 120 dB

Transverse Mode: 70 dB

* Models supplied with isolation transformer.

Standards

- ANSI / IEEE C62.41 Category B3
- NFPA 101
- NFPA 111 Stored Electrical Energy Emergency and Standby Power Systems. Meets SEPSS / ECE / Level 1 and Level 2 criteria for types O, U, A, B, and 10; and Classes up to and including Class 1.5
- NFPA 70 National Electric Code
- FCC Article 15, Subpart J, Class A
- IEC 555

STANDARD COMMUNICATIONS & DIAGNOSTICS

Display Monitor & Diagnostics

The **UltraLITE's** full-featured monitoring system includes:

- Self-test diagnostics.
- Automatic battery test.
- Audible alarms.
- Protected ON / OFF switch.
- Push-to-test.

The **UltraLITE** also has a full complement of indicators:

- Percent load.
- High / low / normal input voltage.
- On battery.
- Percent of battery.
- Check battery.
- Bypass status.
- Alarm status.

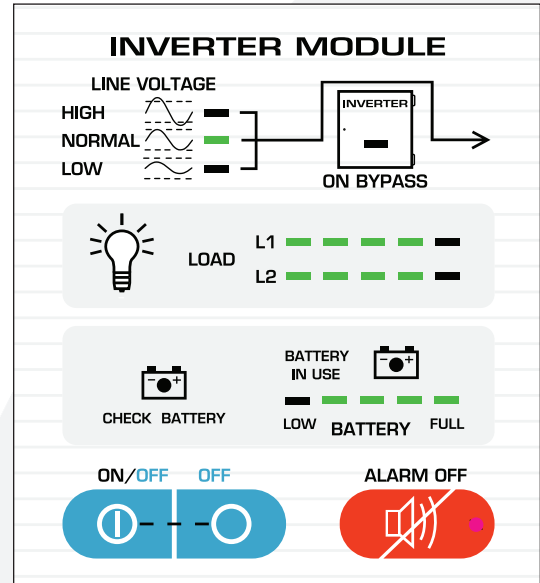

Communications & Diagnostics

- Integral status and alarm panel.
- Remote communications via alarm signals or RS232.

Batteries

- Integral 90 minute, maintenance-free batteries.
- Automatic, pre-programmed battery testing, including self-diagnostics.
- Small footprint and self-contained batteries maximize floor space.
- Rapid recharge, per UL 924 requirements.

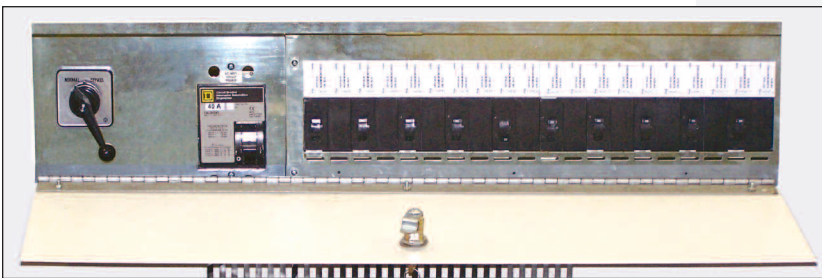

Front-access to standard input breaker, bypass switch, and optional output distribution circuit breakers.

Simplified Maintenance For Centralized Lighting

- Single-point operation. One central inverter controls many lighting circuits.
- Centralized system significantly reduces man-hours required for monthly testing.
- All testing and record-keeping are performed from one location.
- Secure bypass switch allows for uninterrupted bypass of the inverter to utility power for any maintenance situation.
- Eliminates vandalism potential that exists with wall-pack emergency lighting systems.
- Besides its cooling fans, the **UltraLITE** has no mechanical or moving parts.
- Low cost of ownership resulting from: high inverter efficiency, lower maintenance, and optional control device override.

Advanced Digital Monitoring — The *Intellistat*™

(Available for 4.2 kW - 14 kW, all models
and 3 kW - 3.5 kW, excluding 208/120V and 240/120V models)

The user-friendly *Intellistat*™ monitor provides quick, full-access to all of the inverter's features, allows all programming to be done directly from the keypad, and provides complete system diagnostics and testing. An easy-to-read LCD indicates all the electrical parameters, as well as the functional status of the inverter. The keypad allows the entry of date / time values, system setpoints, and password information into the monitor, without the need for an external computer and cable.

The *Intellistat*'s features include:

- LCD display of all electrical parameters.
- NFPA-compliant automatic battery testing / logging.
- User-programmable automatic system testing.
- System alarm annunciation.
- Audible alarm with alarm silence.
- Alarm status display.
- Programmable alarm set-points.
- Date and time display.
- Auto-logging of test results and abnormal events.
- Multi-layer password protection.
- Programmable local interfaces.
- Logs up to 50 events.
- Non-volatile clock and memory.
- Remote monitoring capabilities.
- Optional reporting of test results via fax / e-mail / voice / webpage.
- Optional status notification via e-mail / cell-phone.

Monitored Parameters

The *Intellistat* monitors the following parameters and inverter status indicators:

- Input voltage.
- Output power factor.
- Output voltage.
- Output percent load.
- Output current.
- Output frequency.
- Percent load.
- Battery voltage.
- Output VA.
- Battery charger current.
- Output watts.
- Percent battery time remaining.

Alarms & Status

The *Intellistat* announces many alarms, including the following:

- High / low input voltage.
- Low battery warning.
- High / low output voltage.
- Low battery shutdown.
- High output VA (overload).
- Battery test in progress.
- *Low output VA.
- Auto battery test failed / passed.
- High / low output frequency.
- Off bus status.
- High / low battery voltage.
- DC charger fail / DC open.
- High battery charger current.
- Output circuit breaker open.
- System normal.
- REPO shutdown.
- General alarm.
- System in static bypass.
- System on battery.
- System in manual bypass.

* User-programmable limit referenced during automatic battery testing, to verify integrity of egress lighting.

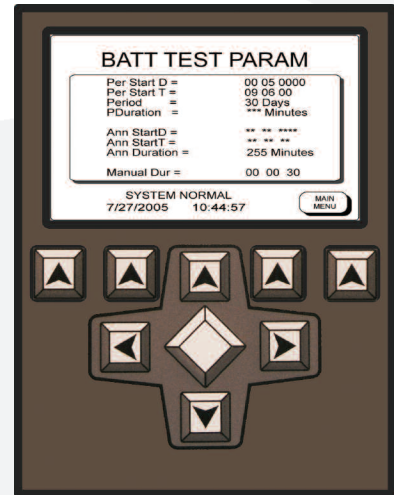

The LCD display on the *Intellistat* provides all electrical parameters, inverter status, programmable inverter and battery testing, remote monitoring and reporting, and data logging. An optional integrated fax modem can be included in the closed-loop communications system.

Egress Lighting Integrity Test

This feature provides the industry's most advanced life safety system test available. The *Intellistat* automatically energizes all life safety circuits, regardless of egress lighting design ("always on" or "normally off") during the required monthly and annual tests. The *Intellistat* then compares power consumption during the test period with user-defined load capacity, analyzes the data, and advises if service is required.

Automatic System Tests

The *Intellistat* automatically performs a user-defined (date and time) 5-minute system test every 30 or 90 days. It also performs user-defined (date and time) 30-, 60-, or 90-minute, or 2- or 4-hour annual system tests. For all of these tests, the *Intellistat* logs the test results with date and time, as well as a "pass" or "fail" indication.

Manual System Tests

The *Intellistat* also allows the user to manually invoke a user-defined system test for 30-, 60-, or 90-minutes, as well as 2- or 4-hours. A 1-minute or 5-minute manual test is also available for "spot inspections".

DESIGN FLEXIBILITIES & PROVEN SOLUTIONS

The **UltraLITE** offers design flexibilities which are not provided with competing lighting inverters:

Multi-Voltage Capabilities (Figure 1)

The **UltraLITE** is a power factor corrected, uninterruptible, double-conversion system, with a static transfer switch for maximum reliability. An internal make-before-break bypass switch maintains the proper output voltage in bypass, even “dual output voltage” configurations. The **UltraLITE** accepts and distributes the industry’s broadest range of voltages, from 120 VAC – 600 VAC.

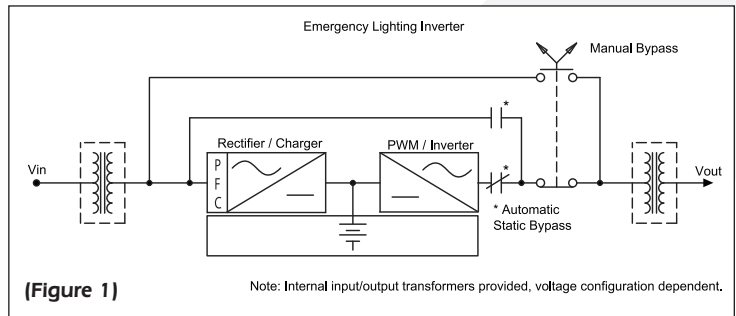

UL 924 Auxiliary Power Supply (Figure 2)

The **UltraLITE** is recognized by UL 924 as an Auxiliary Power Supply for Emergency Lighting, commonly known as UL 924A. This additional UL effort and certification provides the perfect complement to generator-based emergency lighting systems. The **UltraLITE** provides uninterruptible, regulated power to critical lighting systems and other life safety related equipment. Additionally, for uncompromised personal safety, critical “always on” lights remain illuminated, and the generator synchronization delay is eliminated.

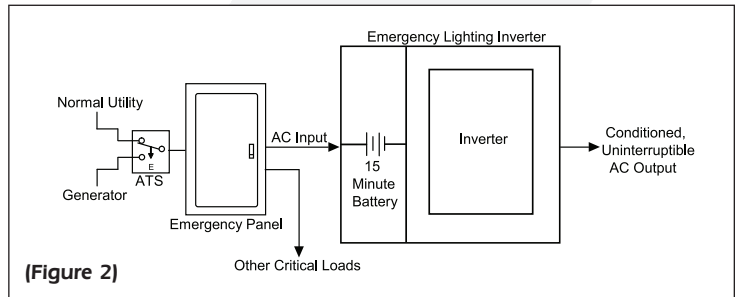

Remote Input Command (Figure 3)

Allows the monitoring of multiple locations and events within the emergency lighting system, and may be activated by a signal from any specified monitoring point. If an unacceptable condition exists at one or more of the locations being monitored, the open contact energizes the “Normally Off” bus, thus illuminating the “Normally Off” emergency lights. Likewise, when normal conditions are restored, the “Normally Off” bus is de-energized, and the emergency lights return to their “Normally Off” state.

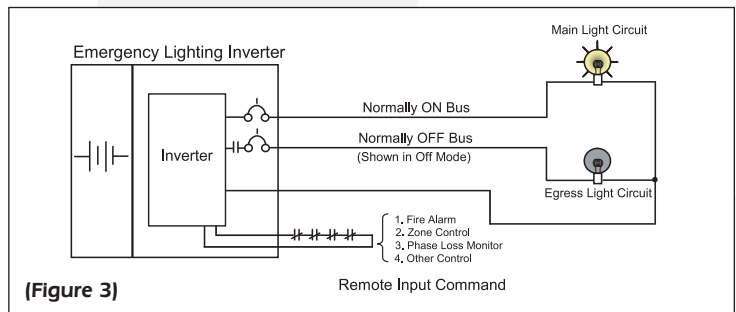

Local Control Device Override (Figure 4)

The **UltraLITE** allows for user control of emergency egress lighting. This includes (but is not limited to) occupancy sensors, wall switches, and dimmer switches. Not only is this approach more reliable, it also saves money because it reduces costly “always on” circuits.

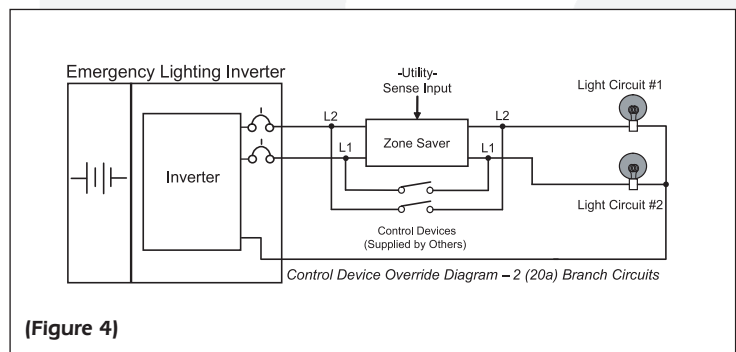

Zone Sensing (Figure 5)

The most cost-effective emergency lighting applications allow for independent activation of “Normally Off” fixtures in multi-floor or multi-use facilities. The **UltraLITE** uses ZoneSaver™ to monitor normal lighting circuit panels for each floor / zone. Failure of the normal lighting circuit panel activates the emergency lighting for that floor / zone only.

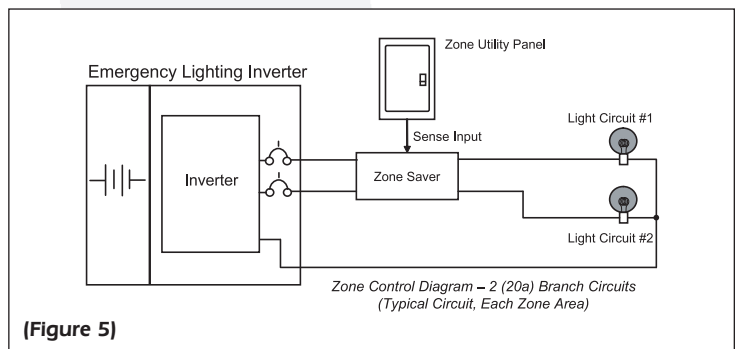

INVERTER OPTIONS & CABINET CONFIGURATIONS

The "UltraLITE" offers a variety of special options:

Normally Off Bus

Provides standby power to "normally off" emergency lamps, at the same or different voltage than "normally on" emergency lamps. When utility power is lost or voltage is inadequate, emergency power is supplied to "normally off" lights, providing a safe means of egress.

Timed Normally Off Bus

Functions the same as the **Normally Off Bus** (above), but differs in that the "Transfer ON" and "Return OFF" times for the bus are programmable. This programmable feature is especially useful to prevent nuisance activation of emergency lighting during short-term power disturbances. Additionally, the return delay provides sufficient time for standard HID lighting recovery, factory-set at 15 minutes.

Automatic Phone Dialer

Plugs into the communications port of the inverter, and can be programmed to notify personnel of alarm conditions. This small device can dial up to four (4) phone numbers (land, cell, pager); and records and delivers a custom voice message.

Output Distribution Circuit Breakers

Meeting the need for flexible power distribution, circuit breakers can be added, subtracted, or moved without any complex mounting techniques. Output circuit breakers can be configured to supply power to different lighting loads at different voltages. Front-access to the standard input breaker and the optional output distribution circuit breakers is through a lockable drop-down panel door.

Lighting Inverter Communications

Optional communications packages enable the user to monitor the inverter on a network, by enabling the inverter to become a node on the network. Status / alarm conditions and / or electrical measurements can be viewed via a web browser or a network management station. Additional communications features include: SNMP, TCP/IP, and MODBUS capability, date / timestamp event logging, and alarm notification.

Front Access Design

The UltraLITE has a compact, space-saving "footprint", and front access to accelerate installation, testing, and maintenance procedures. Standard, 15-year pro-rated batteries are either self-contained or in a user-friendly battery cabinet with easy-access lift-off doors. The "footprint" illustrations below assume unity power factor and 90 minutes runtime. Consult factory for additional front access cabinet configurations using alternative runtimes.

OUTPUT RATING	INVERTER (A)	BATTERY (B)
6kW - 10kW	36"W x 24"D	29"W x 24"D
12.5kW - 14kW		36"W x 27"D



PRODUCT SELECTION GUIDE

MODEL NUMBER GUIDE

PRODUCT	INPUT	OUTPUT	FREQ	kVA / kW	MONITOR	BATTERY	DISTRIBUTION	OFF BUSS
ELU - Lighting Inverter	A=120 J=277 L=208/120 G=240/120 V=347 D=480 E=600	A=120 J=277 Y=277/120 L=208/120 G=240/120 V=347/120	X=60Hz	Lighting Inverters 1.5 kW 7 kW 2.2 kW 7.5 kW 3 kW 8.5 kW 3.5 kW 10 kW 4.2 kW 12.5 kW 5 kW 13.5 kW 6 kW 14 kW	0=Standard 1=Intellistat	S=90m N=None or UPS Battery Option	0=None 1=Yes	0=None 1=Off Buss T=Timed Off Buss

NOTE: Consult factory for output distribution options.

ELU MODEL NUMBERS							
UL 924 MODELS	kVA / kW	WEIGHTS (LBS) ¹ INPUT - OUTPUT VAC 60 Hz 120-120	WEIGHTS (LBS) ¹ INPUT - OUTPUT VAC 60 Hz 277 - 277 277 - 277/120 347 - 347/120 480 - 277 480 - 277/120 600 - 347/120	WEIGHTS (LBS) ¹ INPUT & OUTPUT VAC 60 Hz 208/120V 240/120V	WEIGHTS (LBS) ¹ INPUT - OUTPUT VAC 60 Hz 480 - 240/120V 600 - 240/120V	FULL LOAD BTU'S / HOUR ²	STANDBY MODE BTU'S / HOUR ²
ELU-**X-1.5kW-1S **	1.5	898	1081	na	na	511	128
ELU-**X-2.2kW-1S **	2.2	898	1081	na	na	750	188
ELU-**X-3kW-1S **	3	1073	1256	1073	na	1023	256
ELU-**X-3.5kW-1S **	3.5	1073	1256	1073	na	1194	298
ELU-**X-4.2kW-1S **	4.2	1459	1645	1459	1645	2005	358
ELU-**X-5kW-1S **	5	1548	1734	1548	1734	2387	426
ELU-**X-6kW-1S **	6	na	2654	2404	2654	2864	512
ELU-**X-7kW-1S **	7	na	2654	2404	2654	3342	597
ELU-**X-7.5kW-1S **	7.5	na	2808	2630	2808	3581	639
ELU-**X-8.5kW-1S **	8.5	na	2898	2648	2898	4058	725
ELU-**X-10kW-1S **	10	na	3298	3048	3298	4774	853
ELU-**X-12.5kW-1S**	12.5	na	4124	3684	4124	5967	1065
ELU-**X-13.5kW-1S**	13.5	na	4134	3694	4134	6445	1151
ELU-**X-14kW-1S**	14	na	4576	4136	4576	6684	1194

VOLTAGE CONFIGURATIONS	
**X = Input - Output VAC, 60 Hz	Output KVA / kW
AA = 120 - 120	1.5 kW - 5 kW
JJ = 277 - 277 JY = 277 - 277/120	1.5 kW - 14 kW
LL = 208/120 - 208/120 GG = 240/120 - 240/120	3 kW - 14 kW
VV = 347 - 347/120 DG = 480 - 240/120 DJ = 480 - 277 DY = 480 - 277/120 EG = 600 - 240/120 EV = 600 - 347/120	4.2 kW - 14 kW

Notes: Each model includes 90 minutes back-up time, per UL 924 Emergency Lighting Equipment. Battery runtimes other than 90 minutes are available under UL 924 Auxiliary Power Supplies – consult factory.

Models are listed UL 1778 and cUL Uninterruptible Power Supplies. Consult factory for specific applications and runtimes.

¹ Cabinet weights include the weight of batteries for standard 90 minutes runtime. Battery weights vary according to desired runtimes – consult factory for runtimes other than 90 minutes.

² BTU's are typical at rated load. Consult factory for maximum BTU's / hour ratings on specific models.

³ Standby BTU's represent emergency lighting loads that are normally off or turned off via a local control device, used together with a UL 924 listed bypass relay. Stated BTU's for 120V, 208/120V, and 240/120V models. Consult factory for standby BTU's on other models.

Represented by:

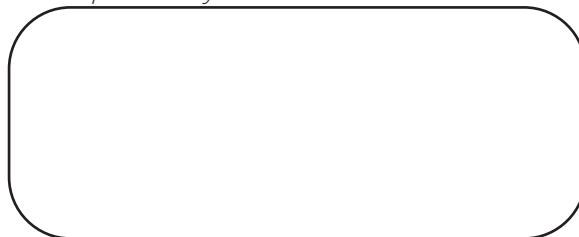

CONTROLLED POWER COMPANY

"World's recognized authority in power treatment"

1955 Stephenson Hwy. Troy MI 48083

www.controlledpwr.com

email: info@controlledpwr.com

Phone: (248) 528-3700 Fax: (248) 528-0411

Call Toll Free: (800) 521-4792